



INSTRUCTIONS 1002-D00 e

Section	1002
Effective	April 2008
Replaces	November 2004

Translation of the
original instructions

S2 - S4C - S6C

transmission



Дистрибутор:
България, София 1528, ул."Поручик Неделчо Бончев" 3, ет.5
+359 2 973 27 67, +359 2 973 2370; office_bg@opwmarket.com

S2 - S4C - S6C TRANSMISSION

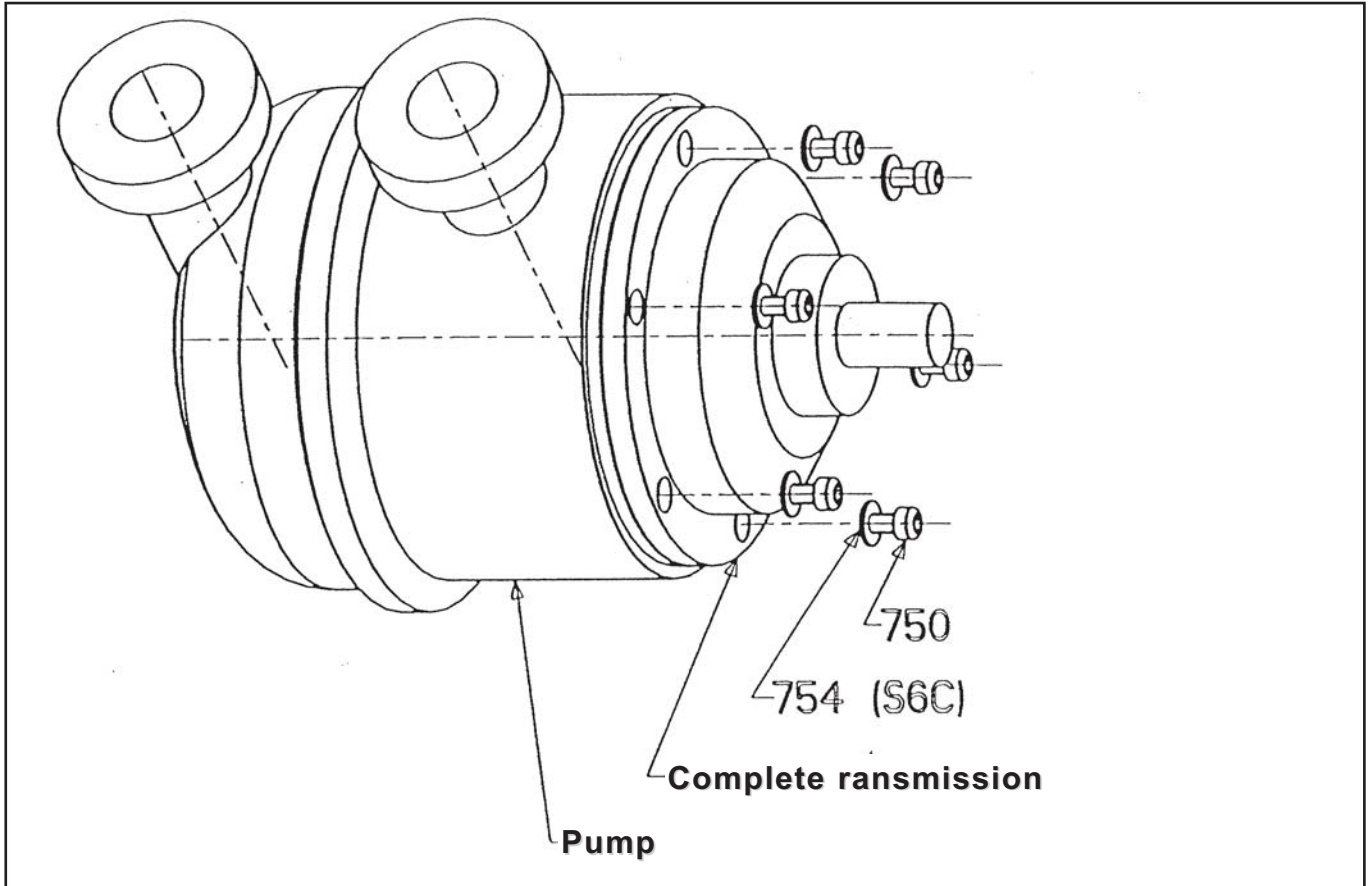

Pump	Screws number	Torque Nm
S2	6 x M6	10
S4C	8 x M8	23,7
S6C	10 x M8*	23,7

All screws must be degreased and mounted with a medium thread locking adhesive (LOCTITE® 2701* for example).

⚠ CAUTION

The assembly torque must be applied progressively in opposition.

* 6 x M8 for old inlet tube

* Loctite® is a registered trademark.