

Temperature Limiting Device (biblades probe)

Additional instructions

for ATEX certified equipment



These MOUVEX Instructions provide assistance for installation but there are not, in any circumstances, intended to replace the specific Instructions of the relevant equipment suppliers. Those Instructions must be read before fitting the equipment.

1. THE EQUIPMENT SUPPLIED

1.1 Isolation amplifier

Galvanic isolation amplifier, 2 different models available: 230 V AC Power supply (or 24 V DC on request). Relay output

The sensor loop is an intrinsic safety electric circuit EEx ia IIC.

Safety level capacity SIL1 to SIL2 in accordance with IEC61508 (amplifier only).

Must be installed in a non classified zone or in an ATEX box if within a classified zone.



1.2 Sensor

Simple temperature sensitive TOR element, to be fixed on the material to be monitored. Should be connected directly to the isolation amplifier or via a cable for intrinsic safety electric circuits (recognisable as BLUE).

In no circumstance can the sensor be used without its isolation amplifier.

The switching point (opening at maximum temperature) is not adjustable. The choice of temperature limit is done according to the temperature class required for ATEX (see table below). The reset point is approximately 30°C (86°F) below the switch point.

Classification of MOVEX certified equipment	Switch point of device installed on the bypass
T5	90°C (194°F)
T4	120°C (248°F)
T3	175°C (347°F)



WARNING

- USE OF THE SYSTEM SAFETY MODE SHOULD BE EXCEPTIONAL (TEMPERATURE LIMIT EXCEEDED ACCIDENTALLY).
- THE COOLING TIME BEFORE RESTARTING DEPENDS ON THE SIZE OF THE EQUIPMENT MONITORED AND THE RESET POINT.

2. DESCRIPTION

2.1 Isolation amplifier

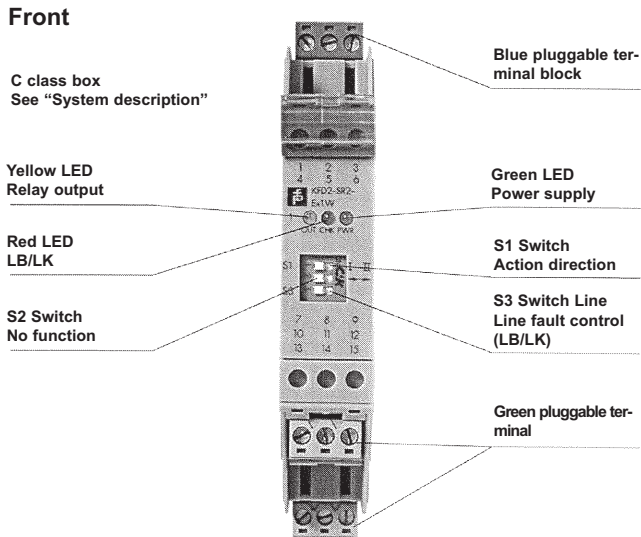

If the amplifier is mounted in a box installed in a non classified zone, the box does not fall under the 2014/34/EU directive. Nonetheless, it should provide sufficient protection for the electric circuit from water and dust.

If the amplifier is mounted in a box installed in a classified zone, the box must comply with the 2014/34/EU directive.

Respect the rules regarding the separation of the Intrinsic Safety circuit from the other circuits.

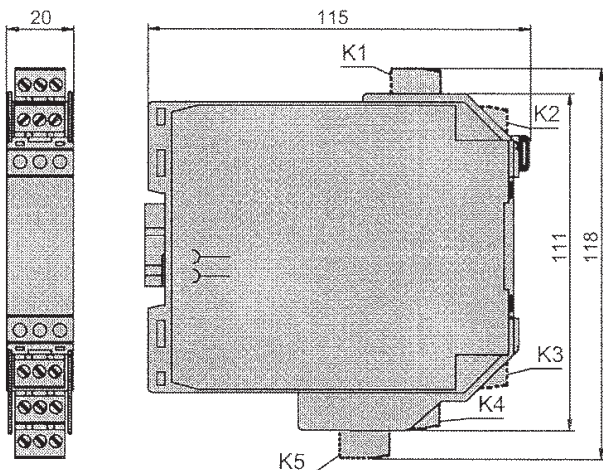

2.2 Sensor

Sensor body in aluminium, to be screw mounted on the equipment to be monitored (without a seal) and greased (with grease compatible with high temperatures), taking care that the sensor body is attached to a paint-free area.

M6 x 8mm fixing. Max tightening torque 8 Nm.

Electrical junction : 2 wires maximum length 1m, without polarity, isolated from the aluminium box.

Switch and reset limits not adjustable.

Average hysteresis 30°C (86°F)

For the junction with the sensor, use the junction box supplied by MOUVEX.

Respect the rules regarding the separation of the Intrinsic Safety circuit from the other circuits.

NOTE :

In order to mechanically protect the sensor's wires, these may be slid into a 4/6 "rilsan" or PTFE tube, which resists the surrounding temperatures.

Several temperature sensors may be connected to the same isolation amplifier (for example: to monitor a pump equipped with a double bypass).

In this case, the temperature sensors are mounted in series. The junction should be made at the connection box.

Junctions examples :

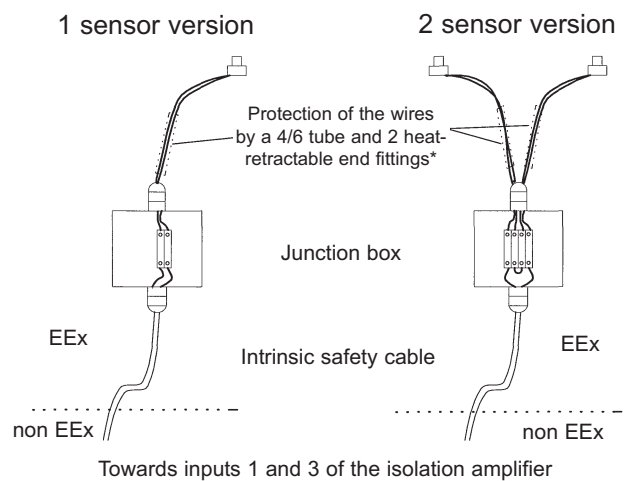

* Assembly is at the customer's expense unless specified as mounted in the purchase order.

2.3 Cable

It is imperative that the cable used to connect the sensor to the amplifier is consistent with wiring for an intrinsic safety circuit (PVC insulation, blue, labelled according to IEC 60079-14) : valid for 200 m.

For longer distances, refer to the insulation amplifier's accompanying instruction notice to calculate the Intrinsic Safety loop.

3. WIRING

Temperature sensor

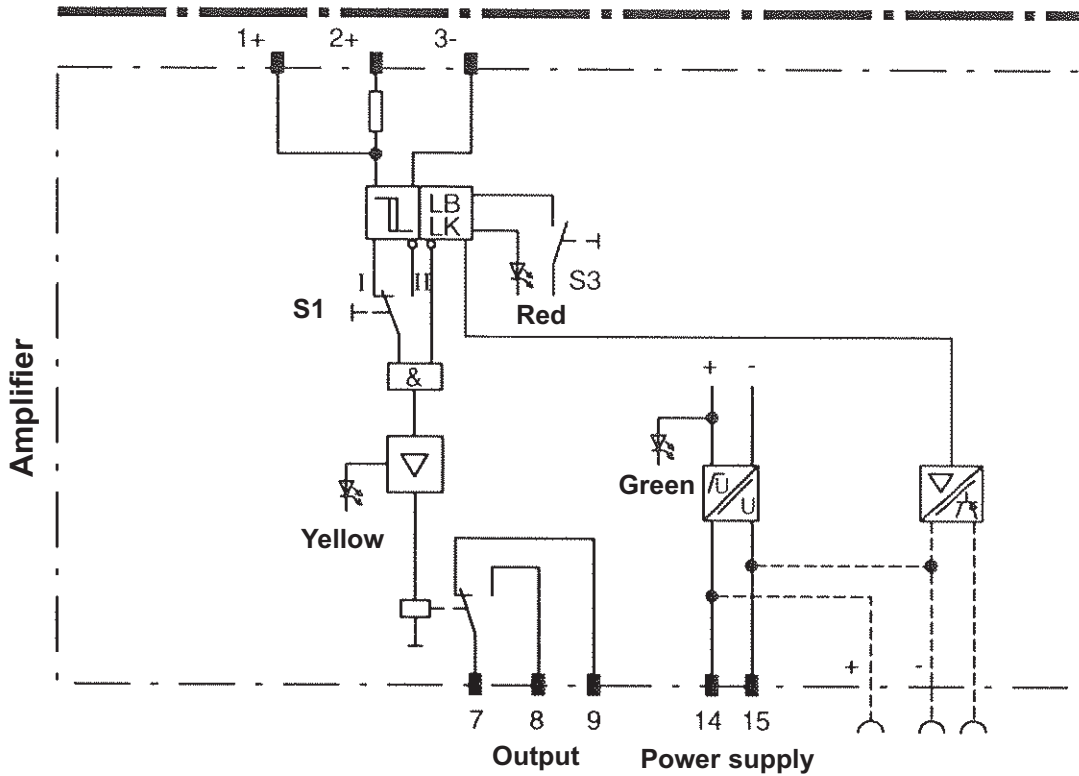

Classified zone

Non classified zone

Power supply (terminals 14 and 15):
 Sensor input (Terminals 1 and 3):
 Relay output (Terminals 7 and 8):

$\pm 10\%$ (or $\pm 15\%$ on request).
 NC contact (circuit open if the max temperature is exceeded).
 NO contact (circuit open if max temperature is exceeded or if the amplifier power supply is absent).
 Max voltage 253 V AC: 2A

Switch S1 in position I (left).
 Switch S2 in position I (left).
 Switch S3 in position II (right).

It is imperative to use :

- a NC sensor wired in 1 and 3,
- the relay output in 7 and 8,
- the switch S1 in position I.

Any other combination is inappropriate and generates a serious risk of malfunction of the temperature limiting device's safety function in the installation.

4. INSTALLATION TESTS

On start-up, it is compulsory to carry out the entire test procedure for the temperature limiting device.

These tests are necessary to ensure that the operation of the installation, and in particular of the temperature limiting device, is effective and safe.

If the test procedure is not scrupulously followed, the risk of malfunction of the temperature limiting device's safety function in the installation is increased.

In that case, safe stopping of the installation is not ensured.

The currents and power used in the intrinsic safety loop cannot cause an explosion.

Hence, it is possible to open the junction box and work on the temperature sensor loop with the power supply on.

TEMPERATURE LIMITING DEVICE TEST PROCEDURE		
	ACTION ...	OTHERWISE...
1. Preliminary control	Before installation and connection	
	a. Check the electrical continuity of the sensor	
	After installation and connection.	
	b. Check visually the mechanical integrity of the amplifier, the sensor and the extension cable.	
	c. Check the position of the 3 switches S1 and S2 in I (left) S3 in II (right).	
2. Power Supply Tests The blue pluggable terminal block K1 (terminals 1 to 3) (sensor), the green pluggable terminal block (terminals 7 to 9) (output), must be disconnected from the amplifier during the test.	Switch power on.	
	a. Check that the green LED PWR is on.	Check the power supply voltage, its polarity (for the 24 V DC model), the fuses.
	b. Check that the yellow OUT LED is off.	Check the position of the S1 switch. Check that the blue pluggable terminal block K1 is unplugged for the test.
	c. Check that the red CHK LED is off.	Check the position of the S1 switch.
	Reconnect the blue pluggable terminal block to the amplifier (the sensor input loop is closed).	
3. Test of the integrity of the sensor and conductors The upper green pluggable terminal block K3 (terminals 7 to 9) (output), must be unplugged for the test.		
	a. Check that the yellow OUT LED is on.	Check the mechanical integrity of the sensor and the extension cable. Check that the wires ending in the blue pluggable terminal block K1 are well tightened in the terminals.
	Disconnect the wire from terminal 1 of the blue pluggable terminal block K1.	
	b. Check that the yellow OUT LED is off.	Check the position of the S1 switch.
	Reconnect the wire to terminal 1. Disconnect the wire from terminal 3 of the blue pluggable terminal block K1.	
	c. Check that the yellow OUT LED is off.	Check the position of the S1 switch.
	Reconnect the wire to terminal 3.	
If a sensor is equipped with an extension cable.	Disconnect a wire from the sensor as close as possible to the sensor.	
	d. Check that the yellow OUT LED is off.	Check the mechanical integrity of the extension cable (short circuit within the cable).
	Reconnect the wire to the sensor. Disconnect the other wire from the sensor as close as possible to the sensor.	
	e. Check that the yellow OUT LED is off.	Check the mechanical integrity of the extension cable (short circuit within the cable).

4. INSTALLATION TESTS (continued)

TEMPERATURE LIMITING DEVICE TEST PROCEDURE		
	ACTION...	SINON...
If the installation is made up of 2 sensors, from one grouping connection terminal and an extension cable	Repeat the preceding test (3d and 3e) for each sensor.	Check the wiring of the grouping terminal.
	Reconnect the green upper pluggable terminal block K3 (terminals 7 to 9) (output) to the amplifier.	
4. Operating test of the power contactors. The 3 pluggable terminal blocks K1 K3 K5 must be connected. The power contactor must be wired and in working order. The power must not be on (motor circuit breaker open)		
	a. Check that, when depressing the start button, the power contactor closes (steady state).	Check the contactor's wiring. Check the wiring of the green upper pluggable terminal block. Check that the yellow OUT LED is on.
	Check that, when depressing the stop button, the power contactor opens (steady state).	Check the contactor's wiring.
	Depress the start button; the power contactor closes (steady state).	
	b. Check that, when disconnecting the green lower pluggable terminal block (terminals 13 to 15) (power supply) of the amplifier, the power contactor opens (steady state).	Check that the green LED PWR is off. Check the contactor's wiring.
	c. Check that, when reconnecting the green lower pluggable terminal block (terminals 13 to 15) (power supply) of the amplifier, the power contactor does not close again (steady state).	Check the contactor's wiring.
The 3 pluggable terminal blocks K1 K3 K5 must be connected. The power contactor must be wired and in working order.		
	Depress the start button; the power contactor closes (steady state).	
	d. Check that, when disconnecting the blue pluggable terminal block K1 (terminals 1 to 3) (sensor input) of the amplifier, the power contactor opens (steady state).	
	e. Check that, when reconnecting the blue pluggable terminal block K1 (terminals 1 to 3) (sensor input) of the amplifier, the power contactor does not close again (steady state).	

**Implementing a periodic control plan of the installation using this procedure is recommended.
We do recommend to do a control at least once a year.**

5. WIRING OF THE INSTALLATION'S STOP START CONTROL

WARNING

- THE WIRING OF THE INSTALLATION (POWER CONTACTOR) MUST BE CARRIED OUT IN SUCH A WAY AS TO ENSURE THAT WHEN THE MOTOR IS STOPPED BY THE TEMPERATURE LIMITING DEVICE IT IS IMPOSSIBLE TO RESTART AUTOMATICALLY.
- SO LONG AS THE TEMPERATURE HAS NOT COME DOWN BELOW THE RESET TEMPERATURE LIMIT, THE LIMITING DEVICE FORBIDS ANY RESTART OF THE INSTALLATION, EVEN VOLUNTARY.

PTB 00 ATEX 2081

Wiring example

